

WC519 Series Crystal



- Ceramic SMD Tuning Fork Crystal
- 32.768KHZ
- RoHS Compliant
- Tape and Reel Packaging Available



Frequency	32.768KHZ
Frequency Tolerance at +25°C	±20 ppm
Load Capacitance	12.5pF
Operating Temperature	-40°C to +85°C
Storage Temperature	-55°C to +125°C
Turnover Temperature	+25°C ±5°C
Stability	-0.035 ppm / (change in °C) ² max parabolic curve
Equivalent Series Resistance	70k Ohms Max
Drive Level	1uW max
Aging	±3 ppm first year
Quality Factor	65000 typ
Shunt Capacitance	1.33pF Max

Part Number Guide

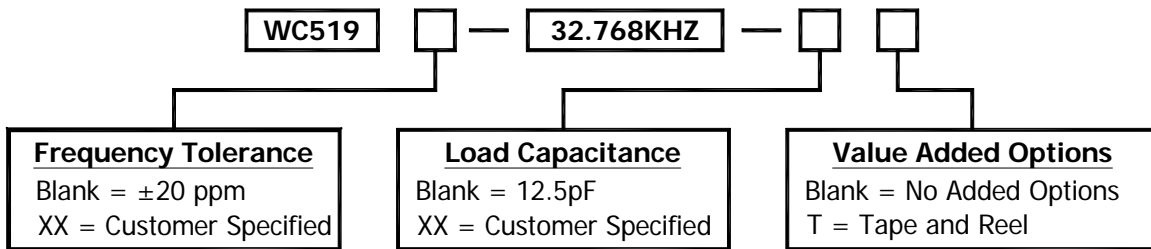

Please consult with MMD sales department for any other parameters or options.



MMD Monitor/Quartztek
 30400 Esperanza, Rancho Santa Margarita, CA, 92688
 Phone: (949) 709-5075, Fax: (949) 709-3536, www.mmdcomp.com
 Sales@mmdcomp.com



Revision: WC156SM092110B

Mechanical Details

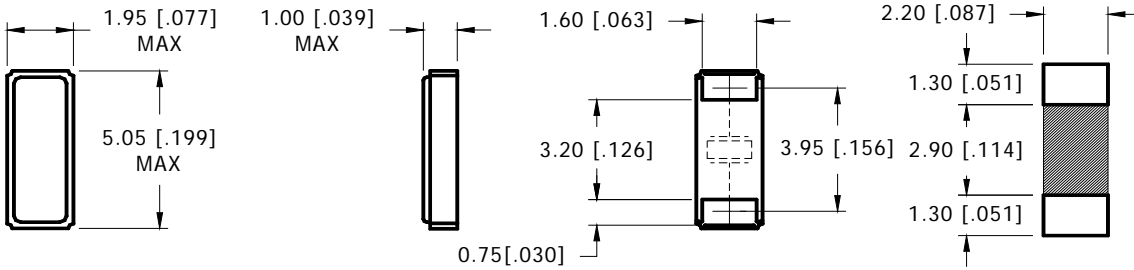

DIMENSION IN BRACKETS ARE IN INCHES

SUGGESTED LAND PATTERN
*DO NOT DESIGN ANY PATTERNS
ON SHADED AREA

Tape & Reel

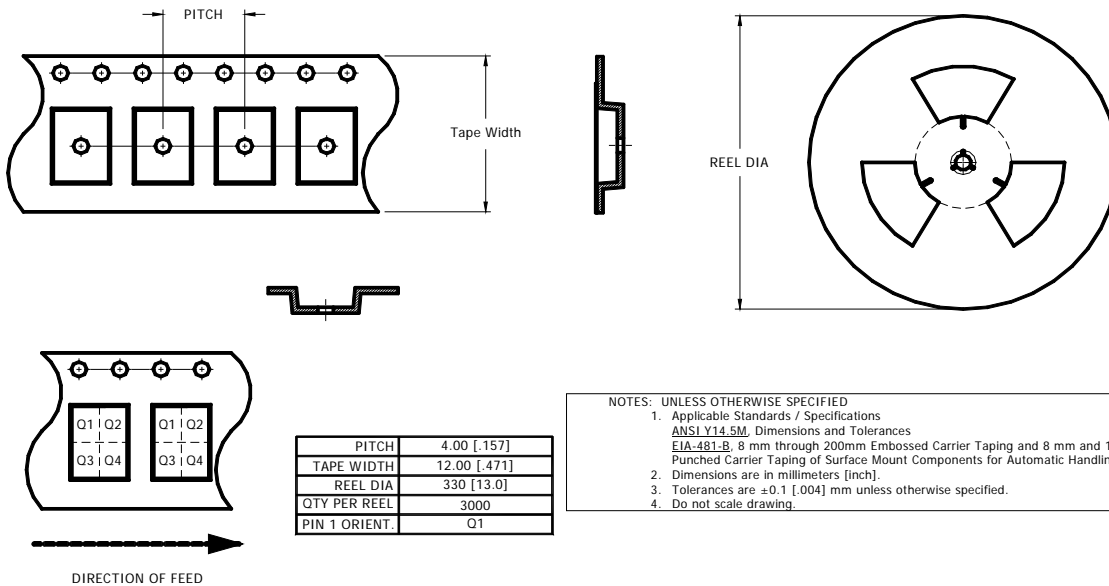

MMD Monitor/Quartztek
30400 Esperanza, Rancho Santa Margarita, CA, 92688
Phone: (949) 709-5075, Fax: (949) 709-3536, www.mmdcomp.com
Sales@mmdcomp.com



Revision: WC156SM092110B